



# TSUN-F26

For proper installation and best possible fit, please read all instructions **BEFORE** you begin.

## Important Safety Information



• **CAUTION** - Before installation ensure proper safety precautions have been made prior to installing this product at heights that require a raised elevation requiring use of a ladder or step stool.

## Contents NOTE: Actual product may vary from illustration. Not to Scale

### Hardware:

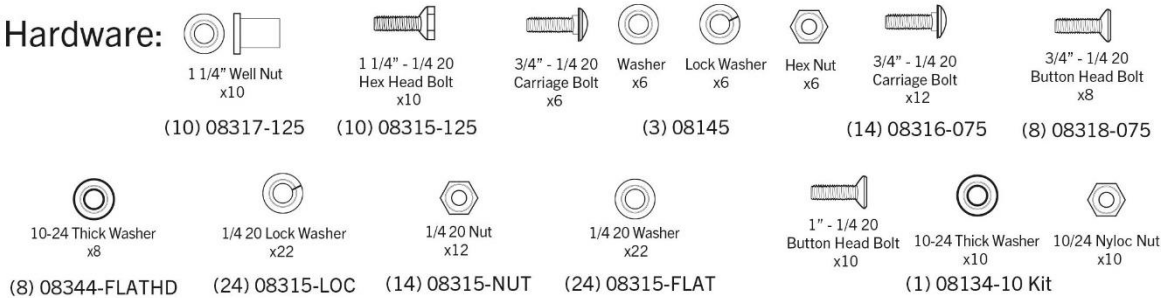

## Contents NOTE: Actual product may vary from illustration. Not to Scale

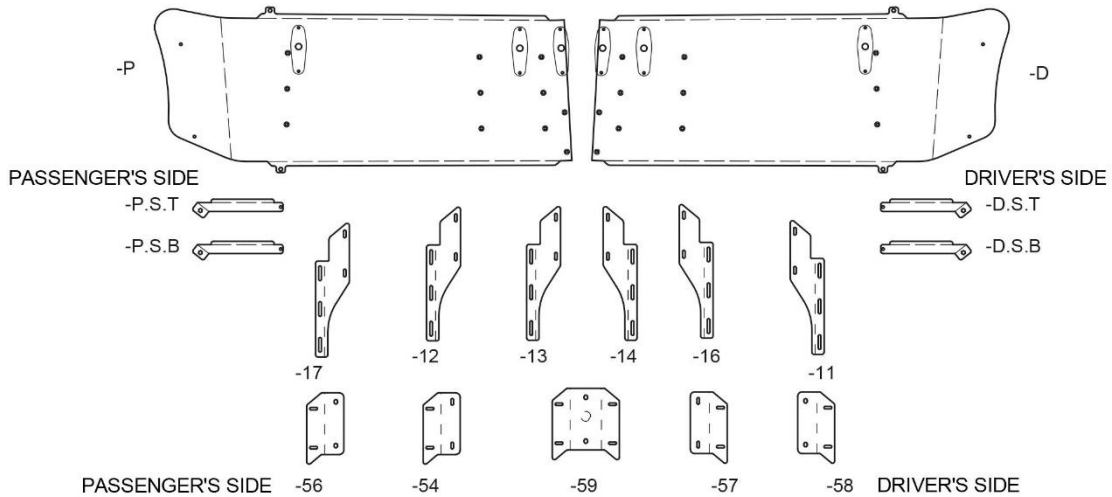

## Tools Required

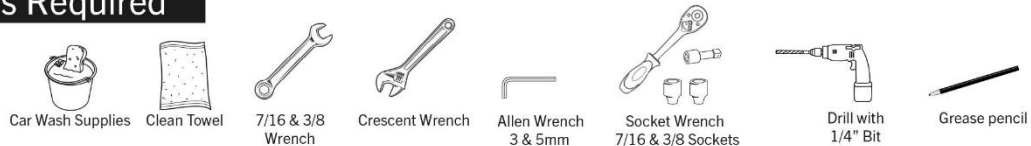

## Installation Steps

NOTE: Actual application may vary slightly from illustrations.



Place the **TRUX ACCESSORIES** visor assembly onto the cab of the truck aligning brackets -56, -59, -58 to the factory holes using the factory hardware from step one. Do not over tighten. Mark the bracket hole locations on brackets -54 and -57 on the cab of the truck using a grease pencil or equivalent. Remove the visor assembly and set aside. Drill the marked locations and install well nuts (08317-125).

3

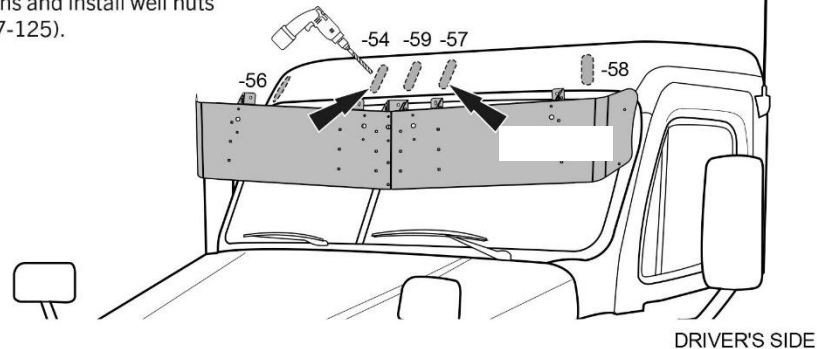

Refit your **TRUX ACCESSORIES** visor assembly to the cab of the truck utilizing all bracket mounting points. Tightening the bolts as adjustments are made for the final fit.

Hardware kits: (08317-125, 08315-125, 08315-flat, 08315-loc), will be used to join brackets -54 and -57 to the cab of the truck to the mounted well nuts.

4

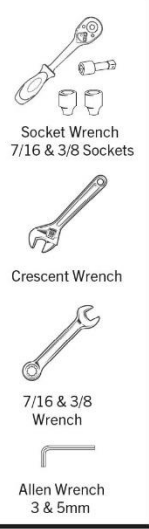
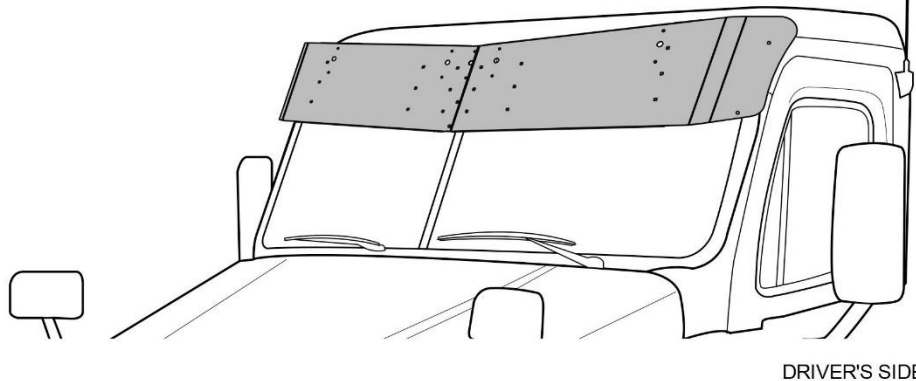

## Care and Cleaning

- Wash and polish your new Visor using premium Detail Products.

premium Detail Products.

The material that your product is made from can be recycled. Please also consider recycling the packaging that your product came in.

## Congratulations!

**TRUX ACCESSORIES** take the utmost pride in our products and want you to enjoy years of satisfaction from your investment. We have made every effort to ensure that your product is top quality in terms of fit, durability, finish and ease of installation.



CASCADIA - TFUN-F26>